



International Journal of Humanities & Social Science Studies (IJHSSS)
A Peer-Reviewed Bi-monthly Bi-lingual Research Journal
ISSN: 2349-6959 (Online), ISSN: 2349-6711 (Print)
Volume-III, Issue-III, November 2016, Page No. 252-268
Published by Scholar Publications, Karimganj, Assam, India, 788711
Website: <http://www.ijhsss.com>

Selection and Work Adjustment of Expatriates in Multinational Corporations

Khikmatullo Kudratov

PhD student in Corporate Management, University of Science & Technology Beijing, People`s Republic of China

Shamsiya Kudratova

PhD student in Management Science and Engineering, University of Science & Technology Beijing, People`s Republic of China

Professor Liu Cheng

Head of Financial Department, Dongling School of Economics and Management, University of Science & Technology Beijing, People`s Republic of China

Abstract

Targeting beyond the dominant emphasis in the expatriate literature, this paper aims to test the relationships among six important variables in the management of expatriates operating in multinational corporations: subsidiary support, cross-cultural motivation, training, personality traits, spouse adjustment and work adjustment. A new model is developed to hypothesize the relationships between these variables and their effects on work adjustment. In total 325 valid questionnaire results were collected from expatriates operating in different multinational corporations and the data was analyzed using SPSS software package.

The survey results demonstrate that all the variables have statistically significant influence on expatriate work adjustment and job performance. In addition, two new variables “country origin” and “education level” was identified with significant relationship among other variables and work adjustment that can be studied in further research.

This study was undertaken in an attempt to contribute to the literature with new integrated model and analyzing hypothesis related to expatriate work adjustment.

Keywords: Work adjustment, Cross-cultural motivation, Expatriate training, Subsidiary support, Multinational Corporation

With the rise of the globalization rate multinational corporations aims (MNCs) is not only to participate in the international market but also to sustain their competitive advantage. Thus lead MNCs to define better strategies to maintain success. One of these strategies for MNCs is to enhance practices on expatriate work adjustment and job performance (Hassan & Diallo, 2013). Expatriate work adjustment and job performance has

a long history that can be traced to the Hawthorne studies (Roethlisberger & Dickson, 1939). Expatriate work adjustment, job satisfaction and job performance has been considered the “Holy Grail” of psychology (Landy, 1989). Hence, this line of research has important implications for MNCs corporate resource allocation. Knowing the expatriates distractions can help management to enhance the cause and adjust expatriate to better job performance (Black, 1988). Significant amount of researches was done in literature with essential emphasizes on expatriate management issues in MNCs (Bateman & Organ, 1983; Black & Mendenhall, 1989; Black & Stephens, 1989; Henne & Locke, 1985).

However, the rapid speed of globalization in the 21st century economy has led organizations to rely on new and better management techniques for international projects in order to sustain their competitiveness in the global market place (Harrison et al., 2004; Huang et al., 2005; Van Vianen et al., 2004). Despite the feasible importance and the long history of research, the failure rate of expatriates in their assignment is high and there are many important unsolved questions regarding expatriate work adjustment and job performance. There are very high rates of expatriate failure in the world -especially in China (Huang et al., 2005). It is challenging for expatriates to be more work adjusted in countries like China due to their unique culture and customs. In order to prevent and lessen expatriate failure rate in a countries with unique culture and customs, we have to find ways to prepare and support expatriate on their settled goals.

Relatively, previous studies have mainly investigated issues on expatriate characteristics, expatriate adjustment, culture differences and other concepts related to expatriate management separately. Whereas, in this research besides other previously tested concepts, we contribute with newly integrated model of six variables. In contrast to other researches, we believe that it is crucial to consider several variables simultaneously rather than selecting expatriates based on one variable neglecting important variables that might lead to expatriate success for work adjustment and job performance.

The primary purpose of this study is to investigate the relationship between the six stage model's concepts: subsidiary support, cross cultural motivation, expatriate training, personality trait, and spouse adjustment for the expatriate effective work adjustment in project implementation. The paper aims to present the integrated model for expatriate work adjustment that would serve as a guideline for successful project implementation in MNCs. The paper also determines some theoretical and practical implications, which is aimed to decrease expatriate failure rate in MNCs.

Furthermore, the paper identify the most important factors among several variables that affect the success rate of the expatriates operating abroad by conducting comparative quantitative analysis using statistical software package. Obtaining positive results proves the validity of our multi-variable integrated model on how to subsequently identify and train employees properly to achieve optimal performance in their assignments. A key assumption here is that the expatriate failure rate constitutes an important measure of the effectiveness of expatriation management itself.

Selection and Work Adjustment of Expatriates in ... Khikmatullo Kudratov, Shamsiya Kudratova, Liu Cheng

Achieving these goals, the paper contributes to literature by innovative points to enhance expatriate work adjustment in MNCs.

1. Literature review

1.1. Expatriate job adjustment: With increasing the global competition and the internationalization of the world markets, the expatriation assignment is becoming more and more important and it has led to the key factor of success for MNCs (Hassan & Diallo, 2013). The rise of MNCs could be partly explained by the fact that costs associated with the development and marketing of new products are too great to be amortized only over one market (Bartlett & Ghoshal, 1991). In sense, MNCs are firms that need to be both global and local at the same time (Treven, 2003).

With regards to Internationalization theory, firms internationalize for the variety of reasons, but the assumption is that firms internationalize in an effort to boost profits and performance (Toh & Srinivas, 2012). Hereby, International Human Resource Management faces a lot of challenges that require much affords to fight with. A consequence of this for most MNCs is a human resource department that develops and administers the following policies and practices but across a wide variety of nations, each with its own social, cultural, legal, economic, political and historical characteristics, staffing, training, development, etc. (Bhaskar et al., 2005). According to scholars when MNCs set human resource strategies, must perform the delicate balancing act (Edwards & ferner, 2004; Bhaskar et al., 2005; Huang et al., 2005). They need to strive for consistency in the way they manage their employees, and at the same time adapt to the business practices and more of each different country or region in which they operate(El Akrem et al., 2014; Kammeyer et al., 2011). According to Hodgetts and Luthans (2006a-b), internationalization of business activities has become one of the most prevalent phenomena of current operations in MNCs. Thus, the demands of qualified expatriates to serve in overseas marketplaces have increased. Managing expatriates has become one of the most effective ways to become successful globally (McAllister & Bigley, 2002).

Expatriates carry responsibility of processing in a cross-border organizations, establishing new relations, being adjusted in a new work environment which is not an easy task(Brown, 2008; Cheng & Lin, 2009). The MNCs success is highly relied on the shoulders of expatriates(Takeuchi, 2010).Better-adjusted expatriates are more likely to perform more effectively, because they are more comfortable with various aspects of their jobs and therefore are less fatigued and have more personal resources available to devote to accomplishing work tasks (Hofstede 2001; Bhaskar et al., 2005c). Work adjustment is one of the most proximal predictors of overall expatriate performance. Wang and Takeuchi (2007) shows that study of expatriates in China provides indirect support for our expectation that work adjustment mediates between cross-cultural motivation and job performance in that they declared that work adjustment mediated between broader motivational traits for instance goal orientation and expatriate job performance.

At the top of any list of skills for being successful in international assignment is the understanding of cultural differences (Lount Jr, 2010). Before the question of what factors foster expatriates success in a foreign culture can be answered, we need to understand what constitutes the cultural differences. The most widely known research in the attempt to compare national cultures in terms of broad cultural and value differences is the pioneering work of Geert Hofstede (1980, 1984, 1993; 2001). He identified five dimensions of work-related value differences, which impact the way people, think and behave in work-related situations across cultural borders. These are “power distance, uncertainty avoidance, individualism versus collectivism, masculinity versus femininity and long-term versus short-term orientation”. The strength of Hofstede’s dimensions is that they are based on both a theoretical and a broad international database. In summary, one of the most difficult aspects of foreign assignments, according to Hofstede, is to understand cultural differences. It is also difficult to understand different groups within a nation (Hofstede, & Minkov, 1991).

Expatriate motivation departs from the dominant emphasis on stress and wellbeing (Harrison et al., 2004). Although previous expatriate research has examined motivational constructs as work self-efficiency, but also there is a research on the role of motivational processes in the intercultural encounters (Gelfand et al., 2007). Most of the researches on expatriate motivation have focused on adjustment attitudinal outcomes (Harrison et al., 1996). Therefore, in order to create a more comprehensive understanding of factors that affect expatriate work adjustment, we draw on the effective expatriate management model.

1.2. Effective expatriate management model: In the following part, we delineate a multilevel integrated model of expatriate effectiveness for the better work adjustment. Figure 1 propose that five contextual attributes—foreign subsidiary support, culture distance, training, spouse adjustment, and personality trait—enhance the relationship with the work adjustment and give positive effect on job performance.

Hence, the model also controls for the direct relationships of individual-level perceptions of both support and culture distance with work adjustment, which have been theorized and supported in prior stress-focused expatriate research (Bhaskar et al., 2005b), and training which also have been theorized in prior research on expatriate management (Brewster & Pickard, 1994; Treven, 2003). The literature shows that the companies rarely provide expatriate training, spouse and family support. Thus we decided to cover training and spouse adjustment in our research, because the issue of expatriate training as well as preparation process needs to be examined in a number of important aspects. Personality trait and spouse and children adjustment are also considered as an important attributes effecting expatriate work adjustment.

Fig-1: Expatriate work adjustment model

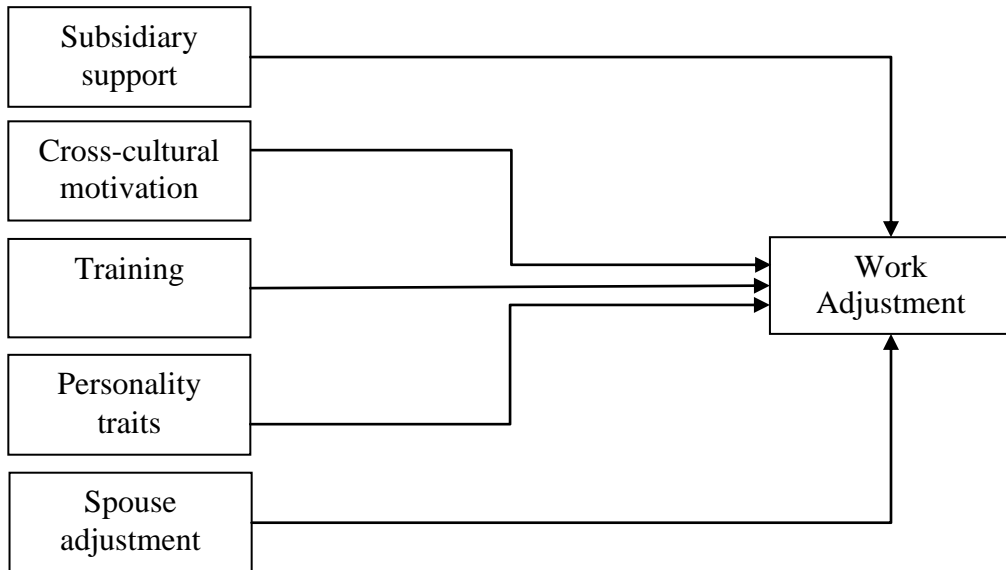

Although previous research has focused on multiple indicators of expatriate effectiveness, but the most critical indicator is expatriate work adjustment (Harrison et al., 2004). This indicator represents distinct facets of expatriate effectiveness. Specifically, work adjustment captures the extent to which expatriates subjectively feel comfortable handling assignment duties like facilitating work meetings, negotiating with vendors and many others. Arguably, from the perspectives of both expatriate and organization, overall job performance is the most important and direct measure of expatriate effectiveness. However, as we explain below, work adjustment can also serve as an intermediate index of expatriate effectiveness, which holds the potential to promote expatriate job performance and, further, mediate the relationship between subsidiary support, expatriate cross cultural motivation, training, personality traits, spouse adjustment.

2. Hypothesis

2.1. Subsidiary Support: Given the complexity inherent in international projects, it is not surprising that some expatriate theories and research have addressed the role of organizational support in expatriate effectiveness (Black et al., 1991; Bhaskar et al., 2005a; Harrison et al., 2004). According to Kraimer and Wayne (2004), three dimensions of organizational support are most relevant and appropriate to expatriate success: (1) adjustment support (i.e., helping expatriates and their families adapt in their international project), (2) career support (i.e., offering guiding related to their career), and (3) financial support (i.e., providing monetary incentives and assistance). They found that individual perceptions of adjustment, financial, and career support are directly and positively related to expatriate adjustment and commitment during project implementation. Accordingly, we conceptualize subsidiary support as a multidimensional construct consisting of adjustment,

Selection and Work Adjustment of Expatriates in ... Khikmatullo Kudratov, Shamsiya Kudratova, Liu Cheng
financial, and career support dimensions. That is, the three dimensions more fully include overall subsidiary support than does each dimension individually.

Following trait activation theory, Tett and Burnett (2003) propose that if subsidiaries are less supportive, it will increase the salience of trait-relevant cues and represent situations that are more relevant to cross-cultural motivation. It is possible that higher levels of subsidiary support can also serve as a stress-buffering mechanism, enabling expatriates to allocate more effort toward accomplishing job-related tasks (Bacharach et al., 2008), thus enhancing the relationship between cross-cultural motivation and work adjustment. Although we are not aware of prior empirical researches that examined the moderating influence of supportive contexts, the theoretical rationale stated above leads us to summarize that:

Hypothesis 1: Subsidiary support has positive impact on work adjustment.

2.2. Cross-cultural motivation: Cultural distance is an important antecedent of MNCs performance. Some researchers claimed that when there is a greater cultural difference between home and host country of expatriates, they would have more difficulty in adjusting (Black et al., 1991). Researchers have recognized that foreign subsidiaries differ in the extent that they require expatriates to adapt to new cultural environments (Harrison et al., 2004). These differences are captured in what has been termed 'cultural distance' (Shenkar, 2001) a construct that denotes differences in basic aspects of culture between a host and home country, including core values, beliefs, customs, and rituals, as well as legal, political, and economic systems (Hofstede, 1983; Adler, 2008). According to models of expatriate adjustment in previous researches, adjustment is more challenging when the host country is more culturally distant (Black et al., 1991; Ronen et al., 1985). Therefore, the study conceptualize cultural distance as a foreign subsidiary– level construct to capture the collective consensus of expatriate that the host country in which their subsidiary located is culturally different from their own home countries.

International projects are quite challenging and require expatriates to devote substantial effort to adapt and perform effectively, in part because of the different cultural context of the foreign operation. Motivation consists of the psychological processes that determine the direction, intensity, and persistence in the action (Kanfer 1990), and it involves the processes by which individuals marshal personal resources (e.g. skills, time, attention) to choose and accomplish work-related goals. In previous literature motivation is identified proximal cognitive predictors of some motivational processes, such as self-efficacy and intrinsic motivation (i.e. interest in a task) (Deci et al., 1989). To be more specific, employees who are both more efficacious and intrinsically interested in their tasks are more likely to actively engage in work-related tasks as well as devote more effort and time toward task accomplishment (Kanfer, 1990; Kanfer et al., 2008).

In prior work on self-efficacy (Bandura, 1997), intrinsic motivation (Deci et al., 1989), and motivational cultural intelligence (Ang et al., 2007), the study propose that expatriates who have higher cross-cultural motivation will be more likely to proactively direct and

Selection and Work Adjustment of Expatriates in ... Khikmatullo Kudratov, Shamsiya Kudratova, Liu Cheng

sustain efforts toward adjusting and adapting to their international project implementation process. Further, there is more specific empirical evidence that motivational cultural intelligence positively relates to expatriates' work adjustment (Ang et al., 2007).

Beyond initial evidence that cross-cultural motivation related positively to work adjustment, (Ang et al., 2007) it's directed to enhance job performance. However, prior research has yet to empirically examine the mediating mechanisms through which expatriate cross-cultural motivation might promote expatriate job performance in international project. Understanding the host culture and being able to communicate freely with employees will ease the work pressure and brings the expatriate closer to the goal. Therefore, we propose the following hypothesis:

Hypothesis 2: Cross-cultural motivation is positively related and influences work adjustment.

2.3. Expatriate training: In the area of cross-cultural awareness in international projects, a very significant focus has been upon the training and preparation of managers, executives and other professionals (Moran & Harris, 1987). The prescriptive and empirical work has widely supported the use of cross-cultural training for expatriates and accompanying family members as an effective means of improving expatriate project success and overall MNCs productivities (Black et al., 1991).

According to the literature, researchers (Shen et al., 2004) proposed three types of international trainings: preparatory training for expatriates; post-arrival training for expatriates training for host-country nationals (HCNs) and third-country nationals (TCNs). These three types of training are very important for expatriates, in preparatory training important step is candidate selection and after that expatriates should be provided with technique trainings. In post-arrival training expatriates should be provided with language training and management trainings for coping effectively with cultural misunderstandings except some cultural distance matters. Black and Mendenhall (1991), have posited that less training of expatriates such as language training may be appropriate where the expatriate comes from a culture that is similar to that of the host country. Besides, cultural training helps individuals to adjust quicker to the new culture and to be more effective in their job performance in project implementation. Expatriate lack of training may lead to failure in their project in a foreign country (Treven, 2003b). Hence we propose the following hypothesis:

Hypothesis 3: Expatriate raining is positively related to expatriate work adjustment.

2.4. Personality traits: Lately curried studies showed that personality traits is very important and affect job performance. Personality trait brings the expatriate closer into a group and makes it easier to find interpersonal relationship. Hence, Mount et al. (1998) implies that, being closer to the group can effectively enhances job performance. It's argued that, expatriates with higher personality traits are more reliable and righteous, earnest and responsible, careful and competitive, hardworking and good at organizing, can perform better in most areas (Barrick & Mount, 1991; Tett et al., 1991). Meanwhile, having good

Selection and Work Adjustment of Expatriates in ... Khikmatullo Kudratov, Shamsiya Kudratova, Liu Cheng

characteristics are energetically leads to participation, feel confident in putting forward their views, and high level of understanding enhances job performance (Barrick & Mount, 1993; Schmit et al., 2000). Expatriates with emotional stability have positive impact on job performance. They can handle pressure well to endure frustrating from the jobs. Simultaneously they are more likely better at the task accomplishment than are neurotic people (Peltokorpi, 2008). Moreover, Topolinski and Hertel (2007) found, openness to experience directs to work adjustment, which leads to better job performance. Expatriates who hold this personality are more active, curious, and open to discussion and development; they are more independent and more likely to create job satisfaction. Furthermore, Bostjancic (2010) showed that managers that has effective control over their emotions are better at their job and gets higher job performance from expatriates. Emotional stability is an important factor on job performance indicates (Foulkrod et al., 2010). Emotional stability, good characteristic, agreeableness, conscientiousness are all impacts work adjustment in Asian societies (Templer, 2012).

Hypothesis 4: Personality trait has positive relationship with work adjustment.

2.5. Spouse and children adjustment: Paying a significant attentions and support expatriates family is essential for MNCs which leads to a better work adjustment.

Well-adjusted spouse and children will influence expatriates in a positive manner with the facilitation of acculturation and adjustment procedure (McCaughey & Bruning, 2005). Expatriates may have apprehensions about whether their children`s education will have necessary continuity as well as how the family will adapt to customs of another culture. According to Tung (1987), managers indicated that the spouse`s inability to adjust was the number one reason for expatriate failure. The major concern for expatriate`s decisions is their families. Often, it is the spouse normally takes on household responsibilities and child cares concerns, such that every element of which may require operating by new and different rules, different environment and life style. Spouse may be required to make the greatest degree of adjustments with little support from the organizations(McCaughey & Bruning, 2005). The family`s happiness, miserable or exciting experience of their life all depends on the spouse (Black & Gregersen, 1991). A number of expatriate failures are related to the spouse adjustment. Many would want to have a split home on a dead end street with a big yard, where their children could play, the cotton bread, the prepared foods, etc. (McCaughey & Bruning, 2005).

Hypothesis 5: Spouse adjustment is strongly related to work adjustment.

3. Methods

3.1. Sample: The data were collected from expatriates operating in different industries around the world. The questionnaire is divided into three parts: demographic information, enterprise background and expatriate performance in MNCs. The third part of the questionnaire consists of six subsections: work adjustment, subsidiary support, cross-cultural motivation, expatriate training, spouse adjustment and personality trait. Seven point Likert scales are used, with 1 representing totally disagree and 7 being totally agree.

The questionnaire was sent to over twenty organizations in different countries. We collected the data from the expatriates operating in different countries with the support of teachers, family, and friends, e.g., although the data were collected with the help of intermediaries, we are not able to report the exact response rate. The survey was conducted from September 2015 to February 2016. A total of 387 questionnaires were received. Subtracting 62 invalid questionnaires, the remaining 325 valid questionnaires represented, an 81 per cent of response rate were used in subsequent analysis. Most of the respondents were well educated with 39.8% having master's degree or above, 35.1% a bachelor's degree, 20.2% college education and the rest 4.9% were finished high school or technical schools. The larger percentage expatriates in the sample were female (59.2%) and male (41.8%). In total, the respondents represented 20 different nationalities. Most expatriates were from Asia (70.2%), Europe (14%), North America (9.8%), South America (0.9%), Africa (3.1%) and Australia (1.2%). Companies parent country in which expatriates works are: Chinese (49.5%), Russian (8.9%), European (7.4%), U. S. A. (5.2%), Kazakhstan (5.8%), Tajikistan (5.2%) and the rest from other countries. About 33.5% are wholly-owned venture, 36.6% international joint venture and the rest 29.8% are other type of organizations.

3.2. Data analysis: To measure the relationship among the variables as a preliminary test, we conducted a correlation analysis. The outcome for the means, standard deviations, and inter-correlations among the variables are shown in Table 1. All predicted correlations are strongly significant. The correlations analysis showing that there is a significant relationship between the subsidiary support and work adjustment at: ($r=0.25$; $p<0.01$), cross-cultural motivation and work adjustment ($r=0.18$; $p<0.01$), expatriate training and work adjustment ($r=0.18$; $p<0.01$), spouse adjustment and work adjustment ($r=0.22$; $p<0.01$), personality trait and job adjustment ($r= 0.01$; $p<0.24$). Newly found variable education level showed statistically significant correlations ($r=0.19$; $p<0.01$). Job level, company size, country origin is strongly determined work adjustment with a negative influence. Correlation results showed there is a strong inter-correlation between the variables. The lowest inter-correlation was ($r=-0.01$; $p<0.01$), which is also significant correlation.

We used the SPSS statistical software package to analyze each hypothesis. To test the entire hypothesis, we conducted a multiple linear regression analysis. We used job adjustment as our dependent variable and placed it in a dependent variable spot and all the rest independent variables (education level, job level, company size, company origin, subsidiary support, cross-cultural motivation, expatriate training, spouse adjustment, personality trait) in an independent spot.

Table-1:

Means, standard deviations, and inter-correlations between variables

Construct	Mea	S.D.	1	2	3	4	5	6	7	8	9
	n										
1 Job adjustment	5.39	1.53									
2 Education level	5.08	1.51	0.19								
3 Job level	5.74	1.38	-0.26	0.41							
4 Company size	3.39	1.61	-0.12	-0.34	-0.12						
5 Company origin	3.96	4.35	-0.19	0.09	0.39	-0.2					
6 Subsidiary support	5.82	0.89	0.25	0.02	0.16	-0.17	-0.06				
7 Cross-cultural mot.	5.68	1.08	0.18	0.09	0.02	-0.12	0.02	0.27			
8 Training	5.71	1.19	0.18	0.22	0.1	-0.14	-0.03	0.31	0.22		
9 Spouse adjustment	5.41	1.41	0.22	0.14	-0.01	-0.09	0.06	0.18	0.36	0.19	
10 Personality trait	5.62	1.21	0.24	0.17	-0.1	-0.48	-0.58	0.15	0.16	0.12	0.22

Note: Correlations significant at the **p<0.01 level

4. Results: Table-2 carries results of multiple linear regression analysis. All the variables were used in the regression analysis to predict the model. The overall model explained 20 percent of variance in overall satisfaction, which was revealed to be statistically significant, $p < 0.01$.

An inspection of individual predictors revealed that satisfaction with subsidiary support ($\beta = 0.16$, $p < 0.01$), satisfaction with personality trait ($\beta = 0.14$, $p < 0.01$) and spouse adjustment ($\beta = 0.13$, $p < 0.01$). Higher satisfaction with subsidiary support and personality trait were associated with higher levels of overall satisfaction.

Additionally, cross-cultural motivation ($\beta = 0.04$, $p < 0.01$) and training ($\beta = 0.04$, $p < 0.01$) are also showed significant relationship with the model. The new founded variables: country origin ($\beta = -0.25$, $p < 0.01$) and education level ($\beta = 0.12$, $p < 0.01$) are significantly associated with work adjustment.

Table-2

Multiple linear regression analysis

N=325	b	SE-b	β	Pearson r	sr ²	Structure coefficient
Constant	1.82	0.84				
Education level	0.12	0.05	0.12	0.19	0.01	0.42
Job level	-0.05	0.05	-0.05	-0.02	0.00	-0.58
Country origin	-0.07	0.01	-0.21	-0.19	0.04	-0.26
Enterprise size	-0.10	0.05	-0.10	-0.15	0.00	-0.42
Subsidiary support	0.27	0.09	0.16	0.25	0.02	0.55
Cross-cultural mot.	0.06	0.07	0.04	0.18	0.00	0.40

Training	0.05	0.07	0.04	0.18	0.00	0.40
Spouse adjustment	0.13	0.06	0.13	0.22	0.01	0.49
Personality trait	0.17	0.06	0.14	0.24	0.01	0.53

Note: The dependent variable was job adjustment. $R^2=0.2$

Adjusted $R^2=0.18$ sr^2 - is the semi-partial correlation. $**p<0.01$

5. Discussion: This study applied the expatriate job performance perspective to better understand and bring them closer to work adjustment in order to get maximum job performance. As recommended by Hofstede (1984), we extended the cultural perspective by including additional variables, which hasn't been tested before all together in a same model to determine work adjustment and job performance. In the contest of expatriate work adjustment: subsidiary support, cross-cultural motivation, training, spouse adjustment and personality trait among with the new variables "country origin" and "education level" were found to enhance work adjustment.

As Hypothesized, subsidiary support has positive impact on expatriate work adjustment. Analysis results showed, subsidiary support has the strongest positive impact on expatriate work adjustment among all the predicted variables. Majority of participated expatriates in the survey indicated that company's subsidiary support is crucial for operating and adjusting in new culturally diversified environment. Relatively, foreign subsidiaries differ in the extent that they require expatriates to adapt to new environments (Harrison et al., 2004). The higher levels of subsidiary support can reduce the stress, enabling expatriates to allocate more effort toward accomplishing job-related tasks (Bacharach et al., 2008). Moreover, it is proved that subsidiary support also enhances the relationship between cross-cultural motivation and work adjustment.

The research outcomes showed that, expatriate cross-cultural motivation has positive impact on work adjustment. The extent of cultural distance determines the degree of difficulty expatriate face in their project implementation abroad (Ward et al., 2001). Cultural distance in work-related values increases anxiety and stress among the expatriates that decreases work adjustment. For example, it denotes differences in basic aspects of culture between a host and home country, including core values, beliefs, customs, and rituals, as well as legal, political, and economic systems (Adler, 2008; Hofstede, 1983). Better culturally motivated expatriates were found more likely feel comfortable in a new environment and successful on accomplishing their assignments.

Expatriate training was found to have positive effect on work adjustment. Trained expatriates are more productive on their tasks. First, they are more familiar and effective to the job. Second, because they are trained and understand their task, they may not be strongly influenced being in a new environment. Expatriate cross-cultural training helps expatriate not only to learn and understand his job but also to increase awareness of cultural differences that eases adjustment in a new environment. Expatriates accomplishing three types of international trainings: preparatory training, post-arrival training and training for

Selection and Work Adjustment of Expatriates in ... Khikmatullo Kudratov, Shamsiya Kudratova, Liu Cheng
host-country nationals and third-country nationals are more reliable to work adjustment (Shen et al., 2004). Lack of training may lead to expatriate failure (Treven, 2003b).

Spouse and family adjustment also showed a strong positive impact on expatriate work adjustment supporting the model. Well spouse and family adjusted expatriates found to be more satisfied with their jobs and have better performance results. Most of the expatriates indicated that it's very important for them to be next to their family and have suitable conditions for their spouse and children. McCaughey (2005) declared, well-adjusted spouse and children would influence expatriates in a positive manner with the facilitation of acculturation and adjustment procedure. The spouse's inability to adjust in a new environment was the number one reason for expatriate failure (Tung, 1987).

Personality trait showed the second strongest variable having positive effect on work adjustment. That is, expatriates with higher personality traits are more effective on their task accomplishment and easier to adjust in a new environment. They are more reliable and righteous, earnest and responsible, careful and competitive, hardworking and good at organizing, can perform better in most areas (Barrick & Mount, 1991; Tett et al., 1991). Expatriates with higher personality traits can handle pressure well to endure frustrating from the jobs and they are more likely better at the task accomplishment than are neurotic people (Peltokorpi, 2008).

6. Practical implications: The research results found several important practical implications. First, a very significant relationship between subsidiary support and work adjustment strongly suggest MNCs to enhance activities on supporting their expatriates. Significant number of expatriates participating in our research indicated foreign company support is necessary and has a positive effect on the work adjustment. MNCs can provide mentoring in order to find out expatriates difficulties operating in a different environment and provide the required support.

Second, MNCs should hire expatriates with higher personality traits. The results showed, personality traits are very important aspect for expatriates in order to be successful in their assignments abroad. Expatriates with higher personality traits showed more confidence about themselves and accomplishing their tasks.

Third, they should provide sufficient conditions for expatriate spouses and children. The largest number of expatriate failure rate is due to the lack of insufficiency of spouse and children support (Black & Gregersen, 1991). The MNCs should study expatriates family condition and provide them with spouse and family support if necessary. Spouses make the most important decisions for expatriates continuing their work abroad.

Fourth, the problems with cultural distance maybe reduced by providing expatriates with pre- departure training as well as post arrival trainings. It's very important for expatriates to have basic understanding of their tasks and the host national culture. It makes it easier for them to be more close to the new culture and work adjustment.

Finally, the newfound variables “country origin” and “education level” also showed strong relationships between all the predictive variables and the work adjustment. We suggest the MNCs managers to be more considered about hiring expatriates closer to the company’s country origin with higher educational level. Company origin, whether it’s foreign-owned or host-country companies affect expatriate work adjustment. If it is a host-country company with a few number of expatriate, they may not consider cultural diversity or be inexperienced in managing it, with the consequence that expatriates need to learn and accommodate them to local work order. Expatriates are more easily integrated into their work environment in foreign owned companies (Fabian J.F. & Vesa P. 2011). Well-educated expatriates showed significant results on the work adjustment and job performance. Selecting the right expatriate among several candidates is a crucial task for MNCs. Herein after, MNCs can apply our integrated model as a guideline that is proved significantly, for expatriate management and selecting suitable candidates in order to decrease failure rates and increase profitability.

7. Limitations and suggestions for further research: In order to test the hypothesis, the study was conducted by analyzing survey results of expatriates from 24 countries operating around the world. In order to protect confidentiality of participants, an anonymous survey was conducted in this study. Therefore, we weren’t able to measure the level of influence of each predicted variable on job performance. If privacy concerns could be lessened in the future studies, more objective data such as supervisory ratings helps to validate bilateral relations between work adjustment and job performance. That is, the exact percentage of expatriate participants in the research could be feasible to determine with the level of support they get on each variable and their affects on work adjustment and job performance.

The current study undertook relationships between independent variables: subsidiary support, cross-cultural motivation, training, spouse adjustment, personality trait and dependent variable work adjustment. The research also found new variable education level having significant relationship with the model. Further research can be carried using all these variables and also acceptable to add some control variables to run hierarchical multiple regression testing control over independent variables in order to get better results on work adjustment and job performance.

References:

1. Adler, N. J., & Gundersen, A. (2007). *International dimensions of organizational behavior*: Cengage Learning.
2. Ang, S., Van Dyne, L., Koh, C., Ng, K. Y., Templer, K. J., & Tay, C., et al. (2007). Cultural intelligence: Its measurement and effects on cultural judgment and decision making, cultural adaptation and task performance. *Management and organization review*, 3(3), 335-371.

3. Bacharach, S. B., Bamberger, P. A., & Doveh, E. (2008). Firefighters, critical incidents, and drinking to cope: the adequacy of unit-level performance resources as a source of vulnerability and protection. *Journal of Applied Psychology, 93*(1), 155.
4. Bandura, A. (1997). Editorial. *American Journal of Health Promotion, 12*(1), 8-10.
5. Barrick, M. R., & Mount, M. K. (1991). The big five personality dimensions and job performance: a meta-analysis. *Personnel psychology, 44*(1), 1-26.
6. Barrick, M. R., & Mount, M. K. (1993). Autonomy as a moderator of the relationships between the big five personality dimensions and job performance. *Journal of Applied Psychology, 78*(1), 111-118.
7. Bartlett, C. A., & Ghoshal, S. (1991). Global strategic management: impact on the new frontiers of strategy research. *Strategic Management Journal, 12*(S1), 5-16.
8. Bateman, T. S., & Organ, D. W. (1983). Job satisfaction and the good soldier: the relationship between affect and employee citizenship. *Academy of Management Journal, 25*(4), 587-595.
9. Beehr, T. A., & Newman, J. E. (1978). Job stress, employee health, and organizational effectiveness: A facet analysis, model, and literature review. *Personnel psychology, 31*(4), 665-699.
10. Bhaskar-Shrinivas, P., Harrison, D. A., Shaffer, M. A., & Luk, D. M. (2005a,b,c). Input-based and time-based models of international adjustment: Meta-analytic evidence and theoretical extensions. *Academy of Management Journal, 48*(2), 257-281.
11. Black, J. S., Mendenhall, M., & Oddou, G. (1988, 1989, 1991). Toward a comprehensive model of international adjustment: An integration of multiple theoretical perspectives. *Academy of management review, 16*(2), 291-317.
12. Bliese, P. D., & Jex, S. M. (2002). Incorporating a multilevel perspective into occupational stress research: Theoretical, methodological, and practical implications. *Journal of occupational health psychology, 7*(3), 265.
13. Bostjancic, E. (2010). Personality, job satisfaction, and performance of slovenian managers-how big is the role of emotional intelligence in this? *Studia Psychologica, 52*(3), 207.
14. Brewster, C., & Pickard, J. (1994). Evaluating expatriate training. *International Studies of Management & Organization, 24*(3), 18-35.
15. Brown, R. J. (2008). Dominant stressors on expatriate couples during international assignments. *The International Journal of Human Resource Management, 19*(6), 1018-1034.
16. Cheng, H., & Lin, C. Y. Y. (2009). Do as the large enterprises do?: Expatriate selection and overseas performance in emerging markets: The case of Taiwan SMEs. *International Business Review, 18*(1), 60-75.
17. Deci, E. L., Connell, J. P., & Ryan, R. M. (1989). Self-determination in a work organization. *Journal of applied psychology, 74*(4), 580.
18. Edwards, T., & Ferner, A. (2004). Multinationals, reverse diffusion and national business systems. In *Management International Review* (pp. 49-79): Springer.

19. El Akremi, A., Colaianni, G., Portoghese, I., Galletta, M., & Battistelli, A. (2014). How organizational support impacts affective commitment and turnover among Italian nurses: a multilevel mediation model. *The International Journal of Human Resource Management*, 25(9), 1185-1207.
20. Foulkrod, K. H., Field, C., & Brown, C. V. (2010). Trauma surgeon personality and job satisfaction: results from a national survey. *The American Surgeon*, 76(4), 422-427.
21. Fabian J. F., Vesa P. (2011). Cultural distance and expatriate job satisfaction. *International Journal of Intercultural Relations*, 35 (2) 49-60
22. Gelfand, M. J., Erez, M., & Aycan, Z. (2007). Cross-cultural organizational behavior. *Annu. Rev. Psychol.*, 58, 479-514.
23. Harrison, D. A., Shaffer, M. A., & Bhaskar-Shrinivas, P. (2004). Going places: Roads more and less traveled in research on expatriate experiences. *Emerald Group Publishing Limited*, 125(6), 627.
24. Harrison, J. K., Chadwick, M., & Scales, M. (1996). The relationship between cross-cultural adjustment and the personality variables of self-efficacy and self-monitoring. *International Journal of Intercultural Relations*, 20(2), 167-188.
25. Hassan, Z., & Diallo, M. M. (2013). Cross-Cultural Adjustments and Expatriate's Job Performance in Malaysia. Available at SSRN 2349432.
26. Henne, D., & Locke, E. A. (1985). Job dissatisfaction: what are the consequences? *International Journal of Psychology*, 20(1), 221-240.
27. Hodgetts, R. M., Luthans, F., & Doh, J. P. (2006a,b). *International management: Culture, strategy, and behavior*: McGraw-Hill Companies.
28. Hofstede, G. (1980, 1983, 1984,1990,1993, 2001). *Culture's consequences: Comparing values, behaviors, institutions and organizations across nations*:
29. Hofstede, G., Hofstede, G. J., & Minkov, M. (1991). *Cultures and organizations: Software of the mind* (Vol. 2): Citeseer.
30. Hofstede, G., Neuijen, B., Ohayv, D. D., & Sanders, G. (1990). Measuring organizational cultures: A qualitative and quantitative study across twenty cases. *Administrative science quarterly*, 286-316.
31. Huang, T. J., Chi, S. C., & Lawler, J. I. (2005). The relationship between expatriates' personality traits and their adjustment to international assignments. *International Journal of Human Resource Management*, 16(9), 1656-1670.
32. Johns, G. (2006). The essential impact of context on organizational behavior. *Academy of management review*, 31(2), 386-408.
33. Kammeyer-Mueller, J. D., Livingston, B. A., & Liao, H. (2011). Perceived similarity, proactive adjustment, and organizational socialization. *Journal of Vocational Behavior*, 78(2), 225-236.
34. Kanfer, R. (1990). Motivation theory and industrial and organizational psychology. *Handbook of industrial and organizational psychology*, 1(2), 75-130.

35. Kraimer, M. L., Wayne, S. J., & JAWORSKI, R. A. A. (2001, 2004). Sources of support and expatriate performance: The mediating role of expatriate adjustment. *Personnel Psychology*, 54(1), 71-99.
36. Landy, F. J. (1989). *Psychology of Work Behavior*: Brooks/Cole, Pacific Grove, CA.
37. Lount Jr, R. B. (2010). The impact of positive mood on trust in interpersonal and intergroup interactions. *Journal of personality and social psychology*, 98(3), 420.
38. McAllister, D. J., & Bigley, G. A. (2002). Work context and the definition of self: How organizational care influences organization-basei self-esteem. *Academy of Management Journal*, 45(5), 894-904.
39. McCaughey, D., & Bruning, N. S. (2005). Enhancing opportunities for expatriate job satisfaction: HR strategies for foreign assignment success. *Human resource planning*, 28(4), 21-30.
40. Moran, P. R., & Harris, R. T. (1987). Managing cultural differences: High-performance strategies for today's global manager. *Houston: Gulf*, 402.
41. Mount, M. K., Barrick, M. R., & Stewart, G. L. (1998). Five-factor model of personality and performance in jobs involving interpersonal interactions. *Human Performance*, 11(2/3), 145-165.
42. Parker, S. K., Ohly, S., Kanfer, R., Chen, G., & Pritchard, R. (2008). Designing motivating jobs. *Work motivation: Past, present, and future*, 233-284.
43. Peltokorpi, V. (2008). Cross-cultural adjustment of expatriates in Japan. *The International Journal of Human Resource Management*, 19(9), 1588-1606.
44. Roethlisberger, F. J., & Dickson, W. J. (1939). *Management and the Worker*: Harvard University Press, Cambridge, MA.
45. Ronen, S., & Shenkar, O. (1985). Clustering countries on attitudinal dimensions: A review and synthesis. *Academy of management Review*, 435-454.
46. Schmit, M. J., Kihm, J. A., & Robie, C. (2000). Development of a global measure of personality. *Personnel Psychology*, 53(1), 153-193.
47. Shen, Q., Jiang, J. H., Jiao, C. X., Lin, W. Q., Shen, G. L., & Yu, R. Q. (2004). Hybridized particle swarm algorithm for adaptive structure training of multilayer feed-forward neural network: QSAR studies of bioactivity of organic compounds. *Journal of computational chemistry*, 25(14), 1726-1735.
48. Shenkar, O. (2001). Cultural distance revisited: Towards a more rigorous conceptualization and measurement of cultural differences. *Journal of international business studies*, 519-535.
49. Takeuchi, R. (2010). A critical review of expatriate adjustment research through a multiple stakeholder view: Progress, emerging trends, and prospects. *Journal of Management*, 36(4), 1040-1064.
50. Templer, K. J. (2012). Five-Factor Model of Personality and Job Satisfaction: The Importance of Agreeableness in a Tight and Collectivistic Asian Society. *Applied Psychology*, 61(1), 114-129.

51. Tett, R. P., Jackson, D. N., & Rothstein, M. (1991). Personality measures as predictors of job performance: a meta-analytic review. *Personnel psychology*, 44(4), 703-742.
52. Tett, R. P., & Burnett, D. D. (2003). A personality trait-based interactionist model of job performance. *Journal of Applied Psychology*, 88(3), 500.
53. Toh, S. M., & Srinivas, E. S. (2012). Perceptions of task cohesiveness and organizational support increase trust and information sharing between host country nationals and expatriate coworkers in Oman. *Journal of World Business*, 47(4), 696-705.
54. Topolinski, S., & Hertel, G. (2007). The role of personality in psychotherapists' careers: Relationships between personality traits, therapeutic schools, and job satisfaction. *Psychotherapy Research*, 17(3), 365-375.
55. Treven, S. (2003a). International training: the training of managers for assignment abroad. *Education+ Training*, 45(8/9), 550-557.
56. Treven, S. (2003b). International training: the training of managers for assignment abroad. *Education+ Training*, 45(8/9), 550-557.
57. Tung, R. L. (1987). Expatriate assignments: Enhancing success and minimizing failure. *The Academy of Management Executive (1987-1989)*, 117-125.
58. Van Vianen, A. E., De Pater, I. E., Kristof-Brown, A. L., & Johnson, E. C. (2004). Fitting in: Surface-and deep-level cultural differences and expatriates' adjustment. *Academy of Management Journal*, 47(5), 697-709.
59. Wang, M., & Takeuchi, R. (2007). The role of goal orientation during expatriation: a cross-sectional and longitudinal investigation. *Journal of Applied Psychology*, 92(5), 1437.